

## SELF DIAGNOSIS

### SELF DIAGNOSIS PROCEDURE

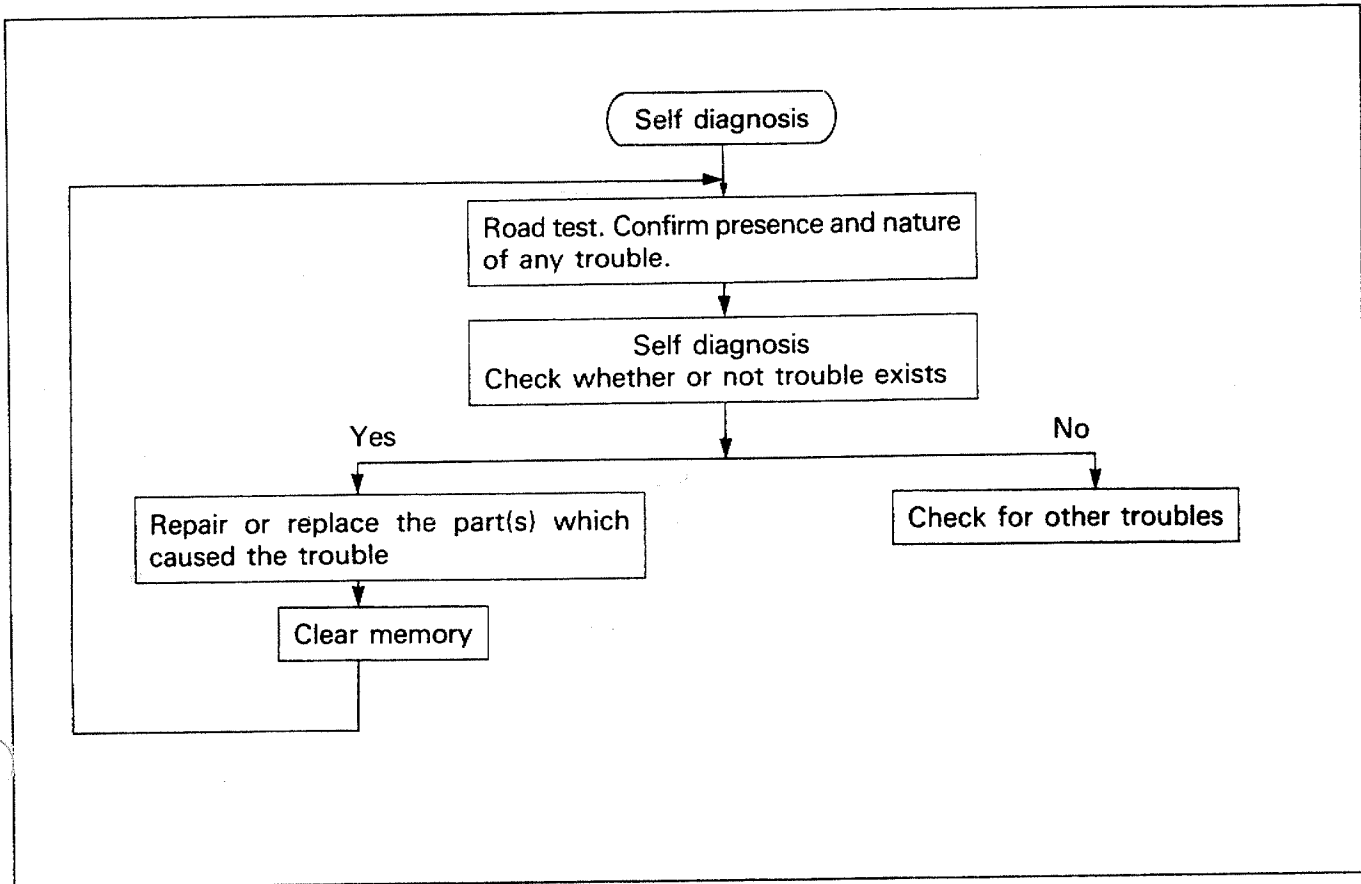

Figure 1. Self diagnosis procedure

### SELF DIAGNOSIS INFORMATION

The transmission control module of this system has the function of self diagnosis. If any trouble occurs in this system, the economy drive indicator light functions to inform operator of possible troubles related to the following 10 components.

1. Vehicle speed sensor-1  
(Installed on the Transmission)
2. Vehicle speed sensor-2  
(Built in the speedometer)
3. Throttle position sensor
4. Shift solenoid A
5. Shift solenoid B
6. Overrun clutch solenoid
7. Lock-up solenoid
8. Automatic transmission fluid thermosensor or battery back-up voltage
9. Engine speed sensor
10. Line pressure solenoid

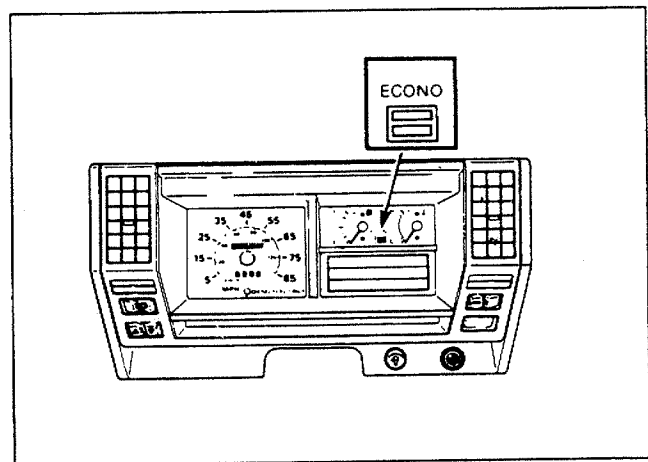

Figure 2. Economy Drive Indicator Light

**Indication of the Indicator Light with the Key Switch Turned On (User Mode)**

When the throttle position sensor, vehicle speed sensor, solenoid, etc., starts to malfunction when the vehicle is running (the key switch turned on), the economy drive indicator light blinks to warn the driver (figure 3).

- The indicator begins to blink as soon as a problem occurs during driving, and keeps blinking until it is corrected.
- The diagnostic trouble code registered in memory cannot be reset by turning the key switch off and on until removing the fuse No. 11 or battery cable.

Condition	Economy drive indicator light display	
	Economy drive switch "Normal" position	Economy drive switch "Economy" position
Normal	<p>Key switch ON</p> <p>ON</p> <p>OFF</p> <p>2.0 sec.</p>	<p>Key switch ON</p> <p>ON</p> <p>OFF</p>
Abnormal	<p>Trouble occur</p> <p>ON</p> <p>OFF</p> <p>3.2 0.4 0.4 0.4 (sec.)</p> <p>Constantly flashings</p>	<p>Trouble occur</p> <p>ON</p> <p>OFF</p> <p>3.2 0.4 0.4 0.4 (sec.)</p> <p>Constantly flashings</p>

**Figure 3. Economy Drive Indicator Light Display**

**Indication of the Indicator Light During Self-Diagnosis (Dealer Mode)**

To help the mechanic locate the problem more easily, the indicator light blinks in different cycles. Each cycle represents one of the ten possible sources of problem.

**Indication of Self-Diagnostic Results**

The diagnostic trouble code registered in memory can be displayed by connecting data link connector of the transmission control module.

The data link connector is located under the brake and clutch fluid tank (figure 4). The white, two-pin connector has a yellow/black wire and a black wire.

- When no problem exists, the display flashes "1" repeatedly (figure 5-A).
- When a malfunction exists, the appropriate diagnostic trouble code is displayed three times repeatedly (figure 5-B).
- When two or more diagnostic trouble codes are registered, they are all displayed three times repeatedly, one at a time, starting with the lowest code number (figure 5-C).

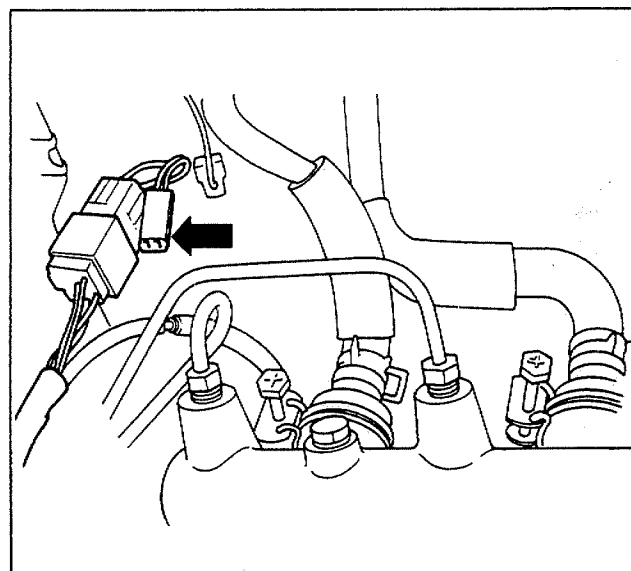

**Figure 4. Data Link Connector**

*EARLY 1988 MODELS HAVE A 6 PIN DIAGNOSTIC CONNECTOR THAT HAS TO HAVE A TECH 1 TO PULL CODES*

# 7A1-22 AUTOMATIC TRANSMISSION

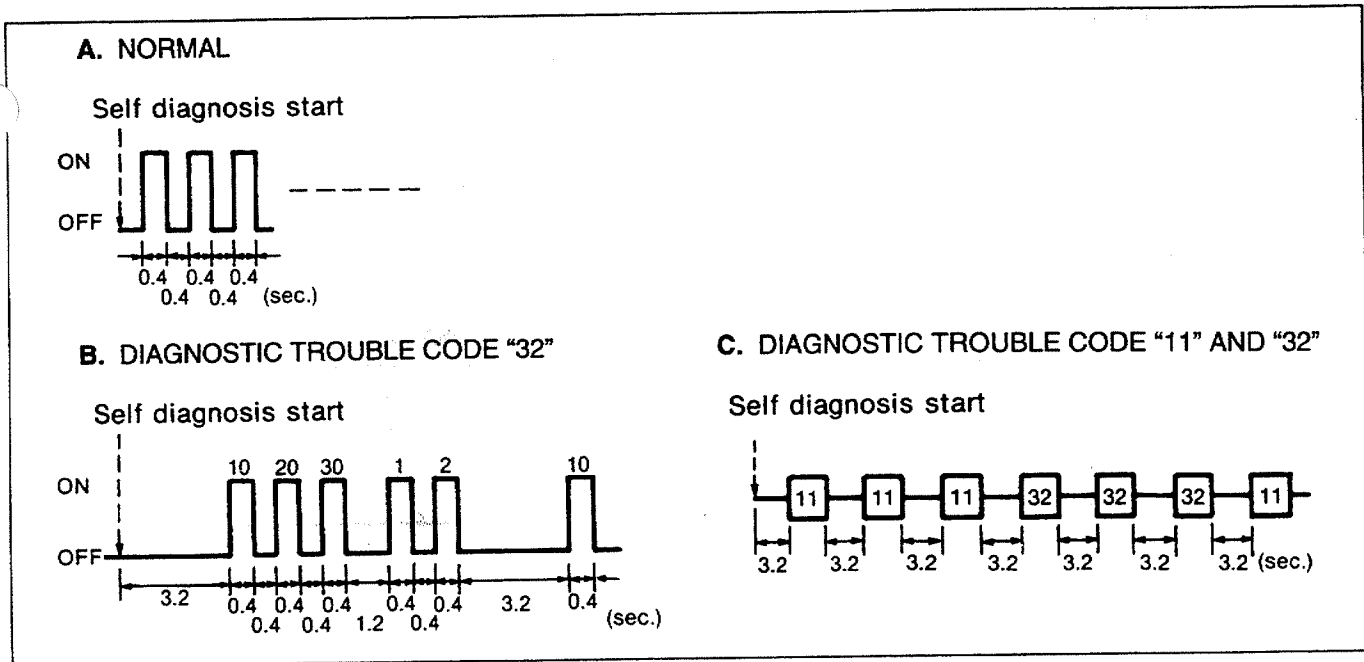

Figure 5. Self Diagnosis Display

## Diagnostic Trouble Codes (DTC)

DTC No.	DIAGNOSIS ITEM	DIAGNOSED CONTENT
11	Vehicle speed sensor "1"	Vehicle speed sensor 1 circuit open or shorted
24	Vehicle speed sensor "2"	Vehicle speed sensor 2 circuit open or shorted
13	Engine speed sensor	Engine speed sensor circuit open or shorted
15	ATF thermosensor or battery back-up voltage	ATF thermosensor circuit open or a voltage drop
17	Inhibitor switch	Inhibitor switch circuit open or shorted
21	Throttle position sensor	Throttle position sensor circuit open or shorted
31	Shift solenoid A	Solenoid circuit open or shorted
32	Shift Solenoid B	
33	Over-run clutch solenoid	
34	Lock-up duty solenoid	
35	Line pressure duty solenoid	

ATF: Automatic Transmission Fluid

32

**CLEARING MEMORY**

- 1) Clear the memory in transmission control module (TCM) by removing Fuse No. 11 or Battery - cable for about 10 seconds, after repairing.  
Otherwise, self diagnosis system continues to display the same trouble as before repairing (figure 6).

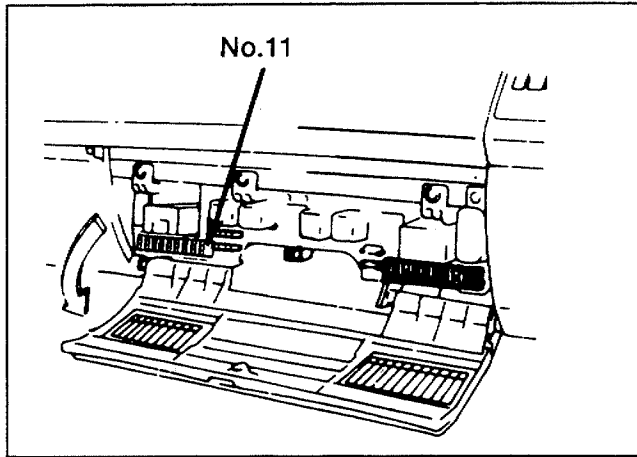

**Figure 6. Clearing Memory**

- 2) Perform the self diagnosis input steps, before road test.  
The first flashing pattern after clearing the memory is rapid flashing ("ON" - 0.1 25 sec, "OFF" - 0.125 sec) (figure 7).
- 3) After the road test is completed, confirm the normal flashing pattern by performing self diagnosis input steps.

**NOTICE:** If the above short flashing pattern is displayed again, by the self diagnosis after the road test, check the circuit for Fuse No. 11

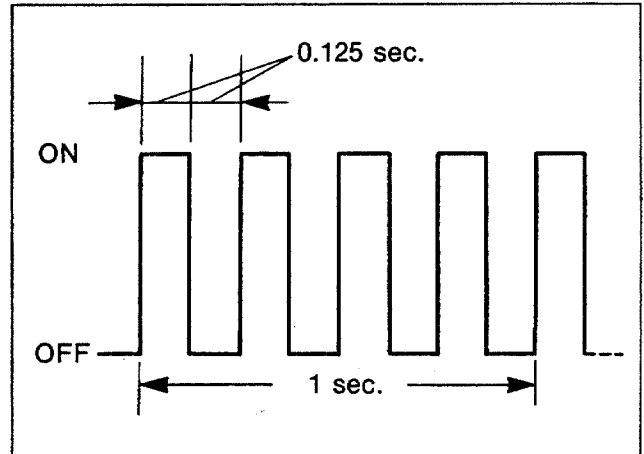

**Figure 7. First Flashing Pattern After Clearing Memory**